



# Open Type Compressors GEA Bock F Series

The full range of open type  
compressors and units

# Advanced competence, in touch with you

In this brochure we present our current program of open type GEA Bock compressors. Always close to our customers' market and process requirements, GEA offers the right compressors for refrigeration and air conditioning in all commercial, industrial and transport sectors.

You will find our open type compressors across today's marine as well as food and beverage industries. Likewise, they support state-of-the-art refrigeration and air conditioning solutions in petrochemical, chemical, pharmaceutical and leisure facility applications.

We develop these compressors as a global refrigeration expert with almost a century of experience. All core components are developed, assembled and tested at our own facilities, always reflecting our enthusiasm for your success. Our worldwide dealer and service network is ready to show you compressors and maintenance solutions for your maximum productivity, wherever you are.

## World-leading technology from GEA

GEA is one of the largest suppliers of process technology for the food industry and for a wide range of other industries. As an international technology group, the company focuses on world-leading process solutions and components for sophisticated production processes.

Long-life, energy-efficient GEA solutions ensure both economical savings and reduced ecological footprint, to help you protect the climate and your standing with customers and authorities.

Be inspired by our state-of-the-art products and the entire passion that goes into each of our components.



PERFORMANCE DATA

		1,740 rpm												
Type	Cond. temp. °C	Cooling capacity $\dot{Q}_0$ [W]						Power consumption $P_e$ [kW]						
		Evaporating temperature °C												
		10	5	0	-5	-10	-15	-20	-25	-30	-35	-40	-45	
F2	30	Q	14,800	12,500	10,400	8,630	7,100	5,780	4,650	3,680	2,870	2,190	1,620	1,140
		P	1.77	1.90	1.95	1.95	1.90	1.81	1.70	1.57	1.43	1.31	1.20	1.12
	40	Q	13,500	11,300	9,440	7,800	6,390	5,180	4,140	3,260	2,510	1,890	1,350	
		P	2.44	2.47	2.44	2.36	2.25	2.10	1.95	1.78	1.63	1.49	1.37	
	50	Q	12,200	10,200	8,440	6,950	5,660	4,560	3,620	2,830				
		P	3.08	3.01	2.90	2.75	2.58	2.38	2.18	1.99				
F3	30	Q	28,600	24,100	20,200	16,800	13,800	11,200	9,000	7,140	5,570	4,250	3,140	2,200
		P	3.44	3.68	3.79	3.78	3.68	3.51	3.29	3.04	2.78	2.54	2.33	2.17
	40	Q	26,100	22,000	18,300	15,200	12,400	10,100	8,020	6,310	4,870	3,650	2,620	
		P	4.74	4.79	4.74	4.58	4.36	4.08	3.78	3.46	3.16	2.89	2.67	
	50	Q	23,500	19,700	16,400	13,500	11,000	8,840	7,020	5,480				
		P	5.97	5.85	5.63	5.34	5.00	4.63	4.24	3.87				
F4	30	Q	57,100	48,200	40,400	33,500	27,600	22,400	18,000	14,300	11,200	8,490	6,270	4,400
		P	6.88	7.36	7.58	7.57	7.37	7.03	6.59	6.09	5.57	5.08	4.66	4.34
	40	Q	52,100	43,900	36,600	30,300	24,800	20,100	16,100	12,700	9,730	7,300	5,240	
		P	9.48	9.59	9.48	9.17	8.73	8.17	7.56	6.93	6.32	5.78	5.34	
	50	Q	47,000	39,400	32,800	27,000	22,000	17,700	14,100	11,000				
		P	11.9	11.7	11.2	10.6	10.0	9.26	8.49	7.74				
F5	30	Q	104,000	87,600	73,300	60,900	50,100	40,700	32,800	26,000	20,300	15,500	11,400	8,000
		P	12.5	13.3	13.7	13.7	13.4	12.7	11.9	11.0	10.1	9.24	8.47	7.89
	40	Q	94,700	79,700	66,500	55,000	45,100	36,500	29,200	23,000	17,700	13,300	9,520	
		P	17.2	17.4	17.2	16.6	15.8	14.8	13.7	12.6	11.5	10.5	9.71	
	50	Q	85,400	71,600	59,500	49,000	39,900	32,200	25,600	20,000				
		P	21.7	21.2	20.4	19.4	18.1	16.8	15.4	14.0				
F76/1570	30	Q	206,000	174,000	145,000	121,000	98,700	80,100	64,200	50,700	39,200	29,600	21,400	14,500
		P	23.3	24.7	25.2	24.9	24.0	22.6	20.7	18.6	16.4	14.1	11.9	10.0
	40	Q	188,000	158,000	132,000	109,000	88,900	71,800	57,100	44,600	34,000	25,000	17,300	
		P	32.2	32.2	31.4	29.9	28.0	25.7	23.1	20.4	17.7	15.2	12.9	
	50	Q	170,000	142,000	118,000	96,800	78,700	63,100	49,800	38,400				
		P	40.1	38.7	36.7	34.3	31.4	28.4	25.2	22.1				
F76/1800	30	Q	236,000	199,000	167,000	138,000	114,000	92,000	73,700	58,200	45,000	33,900	24,600	16,700
		P	26.8	28.4	28.9	28.6	27.6	25.9	23.8	21.4	18.8	16.2	13.7	11.5
	40	Q	216,000	182,000	152,000	125,000	102,000	82,400	65,500	51,200	39,000	28,700	19,800	
		P	37.0	36.9	36.0	34.4	32.2	29.5	26.6	23.5	20.4	17.4	14.8	
	50	Q	195,000	163,000	136,000	112,000	90,300	72,500	57,200	44,100				
		P	46.0	44.4	42.2	39.3	36.1	32.6	29.0	25.4				
F76/2050	30	Q	269,000	227,000	190,000	157,000	129,000	105,000	83,900	66,200	51,200	38,600	28,000	18,900
		P	30.5	32.3	32.9	32.6	31.4	29.5	27.1	24.3	21.4	18.4	15.6	13.0
	40	Q	245,000	207,000	172,000	142,000	117,000	93,700	74,600	58,300	44,400	32,600	22,600	
		P	42.1	42.0	41.0	39.1	36.6	33.6	30.2	26.7	23.2	19.8	16.8	
	50	Q	221,000	186,000	154,000	127,000	103,000	82,400	65,000	50,200				
		P	52.4	50.6	48.0	44.8	41.1	37.1	33.0	28.9				
F76/2425	30	Q	321,000	271,000	227,000	188,000	154,000	125,000	101,000	79,100	61,200	46,100	33,400	22,600
		P	36.4	38.6	39.3	38.9	37.5	35.2	32.4	29.1	25.6	22.0	18.6	15.6
	40	Q	293,000	247,000	206,000	170,000	139,000	112,000	89,100	69,600	53,000	39,000	26,900	
		P	50.3	50.2	49.0	46.7	43.7	40.1	36.1	31.9	27.7	23.7	20.1	
	50	Q	264,000	222,000	184,000	151,000	123,000	98,500	77,700	60,000				
		P	62.6	60.4	57.3	53.5	49.1	44.3	39.4	34.5				
F88/2735	30	Q	361,000	305,000	255,000	212,000	174,000	141,000	113,000	89,000	68,900	51,900	37,600	25,500
		P	41.2	43.6	44.5	44.0	42.4	39.9	36.6	32.9	28.9	24.9	21.1	17.7
	40	Q	330,000	278,000	232,000	191,000	156,000	126,000	101,000	78,300	59,700	43,900	30,300	
		P	57.0	56.8	55.4	52.9	49.5	45.4	40.9	36.1	31.4	26.8	22.7	
	50	Q	298,000	249,000	207,000	170,000	139,000	111,000	87,400	67,500				
		P	70.8	68.4	64.9	60.5	55.5	50.2	44.6	39.0				
F88/3235	30	Q	431,000	364,000	305,000	253,000	207,000	169,000	135,000	107,000	82,200	62,000	44,900	30,400
		P	49.2	52.1	53.2	52.6	50.7	47.6	43.8	39.3	34.6	29.8	25.2	21.1
	40	Q	394,000	331,000	277,000	229,000	187,000	151,000	120,000	93,500	71,300	52,400	36,200	
		P	68.0	67.9	66.2	63.2	59.1	54.2	48.8	43.2	37.5	32.1	27.2	
	50	Q	355,000	298,000	247,000	204,000	166,000	133,000	105,000	80,600				
		P	84.6	81.7	77.5	72.3	66.4	59.9	53.3	46.7				

Relating to 20°C suction gas temperature without liquid subcooling

■ Supplementary cooling or reduced suction gas temp.

TECHNICAL DATA

F

Type	Number of cylinders	Displacement 50 / 60 Hz (1,450 rpm / 1,740 rpm) m <sup>3</sup> /h	Weight <sup>2)</sup> kg	Connections <sup>1)</sup>		Oil charge Ltr.	Speed range rpm
				Discharge line DV mm   inch	Suction line SV mm   inch		
F2	2	10.5 / 12.6	18.0	16   5/8	16   5/8	0.8	960–1,800
F3	2	20.3 / 24.3	28.0	22   7/8	28   1 1/8	1.5	960–1,800
F4	4	40.5 / 48.6	51.0	28   1 1/8	35   1 3/8	2.6	500–1,800
F5	4	73.7 / 88.4	85.0	35   1 3/8	2 x 35   2 x 1 3/8	3.8	500–1,800
F76/1570	6	136.2 / 163.9	220.0	42   1 5/8	54   2 1/8	5.3	500–1,800
F76/1800	6	156.8 / 188.2	217.0	42   1 5/8	54   2 1/8	5.3	500–1,800
F76/2050	6	178.4 / 214.1	213.0	42   1 5/8	54   2 1/8	5.3	500–1,800
F76/2425	6	211.0 / 253.2	209.0	42   1 5/8	54   2 1/8	5.3	500–1,800
F88/2735	8	237.9 / 285.5	312.0	54   2 1/8	76   3 1/8	8.6	500–1,800
F88/3235	8	281.4 / 337.7	306.0	54   2 1/8	76   3 1/8	8.6	500–1,800

<sup>1)</sup> for soldering connections    <sup>2)</sup> version with accessoires

Maximum permissible inclination

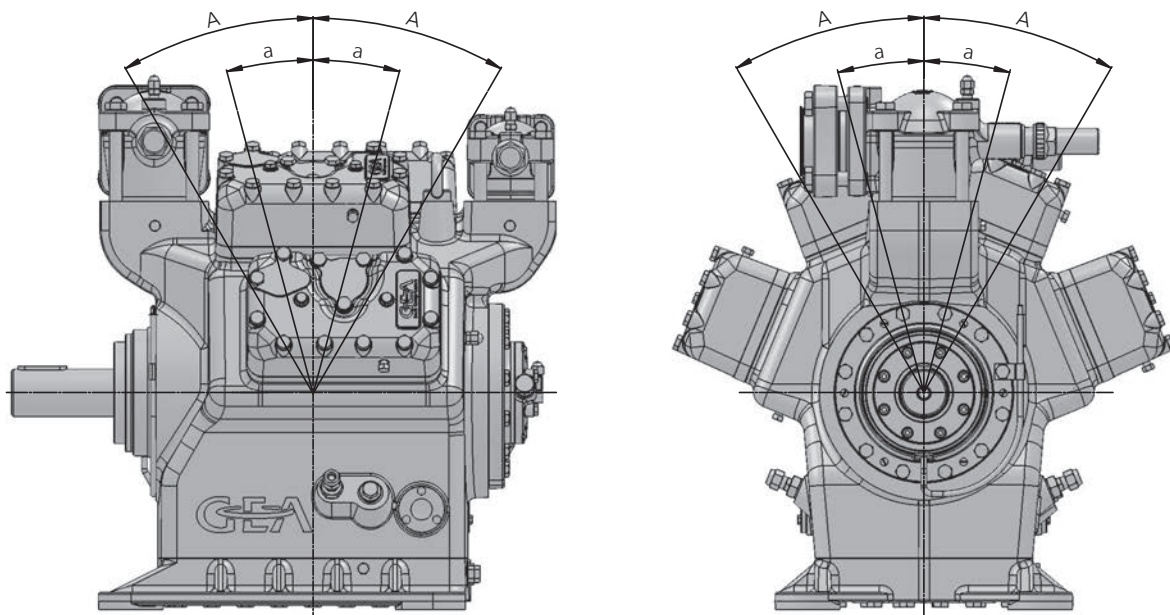

A: max. 30°, max. 2 minutes  
a: max. 15°, continuous operation

F

Type	Oil sump heater	Compressor flywheel	Shaft coupling
	Watt	Ø	WK
F2	40	165 x SPA	42.22
F3	60	210 x SPA	42.22
F4	80	210 x SPA	70.40
F5	80	230 x SPA	70.40
F76/1570		407 x SPB <sup>3)</sup> + 322 x SPB	
F76/1800	140	322 x SPB	80–225
F76/2050			
F76/2425			
F88/2735	200	407.9 x SPB	80–225
F88/3235			

<sup>3)</sup> only valid for F76/1570



Connections		F2	F3	F4	F5	F76	F88
SV	Suction line	Please refer to technical data, page 24					
DV	Discharge line	Please refer to technical data, page 24					
A	Connection suction side, not lockable	7/16" UNF	1/8" NPTF	1/8" NPTF	1/8" NPTF	1/8" NPTF	1/8" NPTF
A1	Connection suction side, lockable	7/16" UNF	7/16" UNF	7/16" UNF	7/16" UNF	7/16" UNF	7/16" UNF
B	Connection discharge side, not lockable	1/8" NPTF	1/8" NPTF	1/8" NPTF	1/8" NPTF	1/8" NPTF	1/8" NPTF
B1	Connection discharge side, lockable	7/16" UNF	7/16" UNF	7/16" UNF	7/16" UNF	7/16" UNF	7/16" UNF
B2	Connection discharge side, not lockable	-	-	-	-	7/16" UNF	7/16" UNF
C	Connection oil pressure safety switch HP	-	1/8" NPTF	7/16" UNF	7/16" UNF	7/16" UNF	7/16" UNF
D	Connection oil pressure safety switch LP	-	1/8" NPTF	7/16" UNF	7/16" UNF	7/16" UNF	7/16" UNF
D1	Connection oil return from oil separator	1/8" NPTF	1/8" NPTF	1/8" NPTF	1/8" NPTF	5/8" UNF	5/8" UNF
E	Connection oil pressure gauge	-	-	-	-	7/16" UNF	7/16" UNF
F	Oil drain plug	R 3/8"	M22 x 1.5	M22 x 1.5	M22 x 1.5	M22 x 1.5	M22 x 1.5
G	Oil sump heater plug	R 3/8"	M22 x 1.5	-	-	-	-
H	Oil charge plug	1/8" NPTF	1/8" NPTF	M22 x 1.5	M22 x 1.5	M22 x 1.5	M22 x 1.5
J	Connection oil sump heater	-	-	M22 x 1.5	M22 x 1.5	M22 x 1.5	M22 x 1.5
K	Sight glass	4 hole M 6	4 hole M 6	4 hole M 6	4 hole M 6	3 hole M 6	3 hole M 6
L	Connection thermal protection thermostat	1/8" NPTF	1/8" NPTF	1/8" NPTF	1/8" NPTF	1/8" NPTF	1/8" NPTF
ÖV	Connection oil service valve	-	-	-	-	1/8" NPTF	1/4" NPTF
p	Connection oil pressure differential sensor	-	-	-	-	M20 x 1.5	M20 x 1.5
Q	Connection oil temperature sensor	-	-	-	-	1/8" NPTF	1/8" NPTF

## SCOPE OF SUPPLY &amp; ACCESSORIES

Scope of supply & accessories		F2	F3	F4	F5	F76	F88
	Open Type reciprocating compressor with suction and discharge shut-off valves	●	●	●	●	–	–
	Two-cylinder, cylinder arrangement in row	●	●	–	–	–	–
	Four-cylinder, cylinder arrangement in V	–	–	●	●	–	–
	Six-cylinder, cylinder arrangement in W	–	–	–	–	●	–
	Eight-cylinder, cylinder arrangement in VV	–	–	–	–	–	●
1	Shaft seal with piece of tube for controlled oil collection	–	–	–	–	●	●
2	Thermal protection thermostat (PTC)	–	–	–	–	○ <sup>2)</sup>	○ <sup>2)</sup>
3	Thermal protection thermostat (bimetal-sensor)	○	○	○	○	○	○
	Oil pump	●	●	●	●	●	●
	Oil pump cover with screw-in option for oil pressure differential sensor ( $\Delta p$ -switch by Kriwan)	–	–	–	–	○	○
	Oil charge: F: FUCHS Reniso SP46; FX: FUCHS Reniso Triton SE55	●	●	●	●	●	●
	Internal Safety valve	–	–	●	●	●	●
	Inert gas charge	●	●	●	●	●	●
	Sight glasses	One	●	●	●	●	–
		Two	–	–	–	–	●
		Three	–	–	–	–	–
4	Oil sump heater 220-240 V - 1 - 50/60 Hz	○ <sup>2)</sup>	○ <sup>2)</sup>	○ <sup>2)</sup>	○ <sup>2)</sup>	○ <sup>2)</sup>	○ <sup>2)</sup>
5	Oil differential pressure sensor ( $\Delta p$ -switch by Kriwan) 220-240 V - 1 - 50/60 Hz	–	–	–	–	○ <sup>1)</sup>	○ <sup>1)</sup>
6	Oil pressure safety switch MP 54 230 V - 1 - 50/60 Hz, IP20	–	○ <sup>1)</sup>	○ <sup>1)</sup>	○ <sup>1)</sup>	○ <sup>1)</sup>	○ <sup>1)</sup>
7	Oil service valve	–	–	–	–	○ <sup>2)</sup>	○ <sup>2)</sup>
	Capacity regulator	1 capacity regulator = 50 % residual capacity	–	–	○ <sup>2)</sup>	○ <sup>2)</sup>	–
		1–2 capacity regulators = 66/33 % residual capacity	–	–	–	–	○ <sup>2)</sup>
		1–3 capacity regulators = 75/50/25 % residual capacity	–	–	–	–	–
	Oil temperature sensor (Pt1000)	–	–	–	–	○ <sup>2)</sup>	○ <sup>2)</sup>
	Electronic motor protection unit INT69G for installation in switch cabinet	–	–	–	–	○ <sup>1)</sup>	○ <sup>1)</sup>
	Start unloader 230 V - 1 - 50/60 Hz, IP65, without check valve, including thermal protection thermostat (bimetal sensor)	–	○ <sup>2)</sup>	○ <sup>2)</sup>	○ <sup>2)</sup>	–	–
	Connection possibility for oil level regulators make ESK, AC+R or Carly	● <sup>4)</sup>	● <sup>4)</sup>	● <sup>4)</sup>	● <sup>4)</sup>	●	●
	Connection possibility for oil level regulators make TraxOil	–	–	–	–	●	●
9	Compressor flywheel (see page 24)	○ <sup>1)</sup>	○ <sup>1)</sup>	○ <sup>1)</sup>	○ <sup>1)</sup>	○ <sup>1)</sup>	○ <sup>1)</sup>
10	Shaft coupling for direct drive	○ <sup>1), 3)</sup>	○ <sup>1), 3)</sup>	○ <sup>1), 3)</sup>	○ <sup>1), 3)</sup>	○ <sup>1), 3)</sup>	○ <sup>1), 3)</sup>
11	Step protection	–	–	–	–	○ <sup>1)</sup>	○ <sup>1)</sup>
	Coupling bell for motor adjustment. For B5/B35 IEC motors, flange centering diameter $\varnothing$ 450	–	–	–	–	○ <sup>1)</sup>	○ <sup>1)</sup>
12	Elevated base plate (F76: 2.7 l, F88: 4.6 l additional oil volume)	–	–	–	–	○ <sup>2)</sup>	○ <sup>2)</sup>
13	Additional fan	–	○ <sup>1)</sup>	○ <sup>1)</sup>	○ <sup>1)</sup>	○ <sup>1)</sup>	○ <sup>1)</sup>

● Scope of Supply (standard)  
○ Accessories  
– Not available

<sup>1)</sup> Enclosure  
<sup>2)</sup> Mounted

<sup>3)</sup> Please state motor  $\varnothing$  and features key groove dimensions when ordering shaft coupling

<sup>4)</sup> Only possible with additional adapter